

# UM-1 (HC80)

## MICROPROCESSOR CRYSTALS / RESISTANCE WELD

### SPECIFICATION

Frequency Range	10 to 150.00MHz
Frequency Tolerance	± 50 PPM ( Standard )
Frequency Stability	± 50 PPM ( Standard )
Operating Temperature Range	0EC to 70EC ( Standard )
Load Capacitance ( CL )	12pF to 50pF & Series
Shunt Capacitance	7pF Maximum
Drive Level	1mWatt Maximum
Aging	±5 PPM per year Maximum

Dimensions in In (mm)

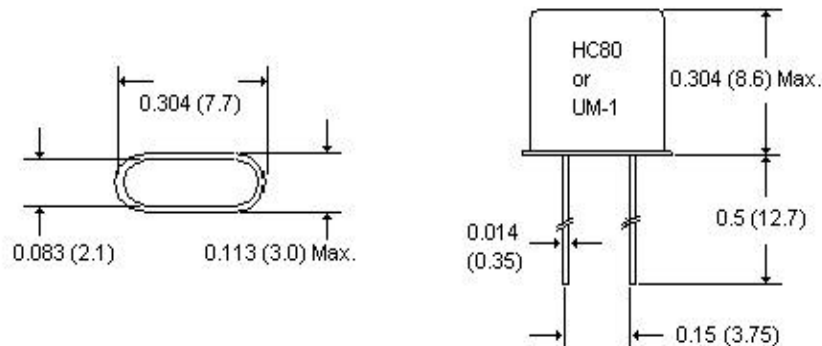

### UM-1 Part Number Break Down

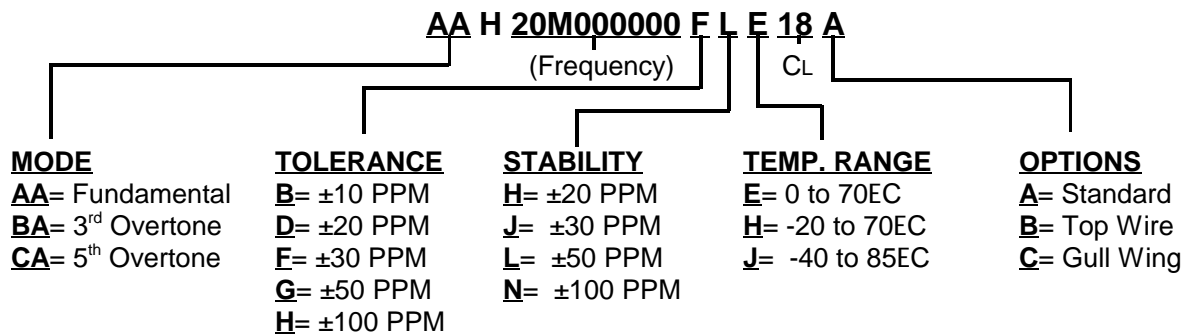

Standard Crystal Corporation 9940 E. Baldwin Place, El Monte, Ca., 91731

Phone: (800) 423-4578, Fax: (626) 443-9049

www.standardcrystalcorp.com, E-Mail: stdxtl@pacbell.net